

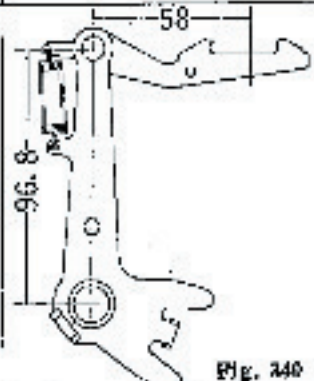

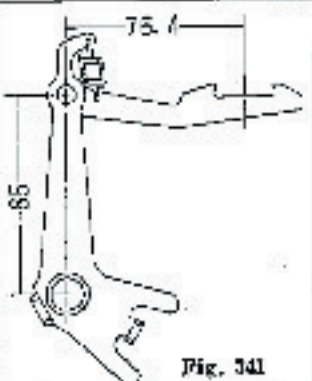

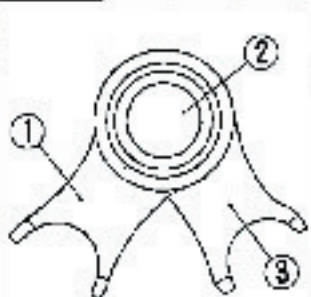
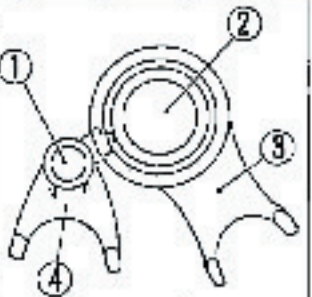

Unit: mm

Part or Item	Model CS500	Model CB500	Modified part:									
Gear shift spindle	 <p>Fig. 340</p>	 <p>Fig. 341</p>	<ul style="list-style-type: none"> <li>• Gear shift spindle</li> </ul>									
Gear ratio	<table border="1"> <thead> <tr> <th>No. of teeth</th> <th>Part name</th> <th>No. of teeth</th> </tr> </thead> <tbody> <tr> <td>64</td> <td>Primary driven gear</td> <td>68</td> </tr> <tr> <td>23</td> <td>Primary drive gear</td> <td>24</td> </tr> </tbody> </table>		No. of teeth	Part name	No. of teeth	64	Primary driven gear	68	23	Primary drive gear	24	
No. of teeth	Part name	No. of teeth										
64	Primary driven gear	68										
23	Primary drive gear	24										
Gear shift fork shaft (Added)	 <p>Fig. 342</p> <ul style="list-style-type: none"> <li>① Right and left gear shift forks</li> <li>② Gear shift drum</li> <li>③ Center gear shift fork</li> </ul> <ul style="list-style-type: none"> <li>• All forks are installed to the drum.</li> </ul>	 <p>Fig. 343</p> <ul style="list-style-type: none"> <li>① Gear shift fork shaft</li> <li>② Gear shift drum</li> <li>③ Center gear shift fork</li> <li>④ Right and left gear shift forks</li> </ul> <ul style="list-style-type: none"> <li>• The center fork is installed to the drum and the right and left forks to the fork shaft.</li> </ul>	<ul style="list-style-type: none"> <li>• Right gear shift fork</li> <li>• Left gear shift fork</li> <li>• Center gear shift fork</li> <li>• Gear shift fork shaft (Added)</li> </ul>									
Gear shift drum	 <p>Fig. 344</p> <ul style="list-style-type: none"> <li>① Groove for gear shift drum guide screw</li> </ul>	 <p>Fig. 345</p> <ul style="list-style-type: none"> <li>② Press bearing in bore</li> </ul> <ul style="list-style-type: none"> <li>• The groove for the drum guide screw was abolished. Instead a 1600S radial ball bearing was pressed in.</li> </ul>	<ul style="list-style-type: none"> <li>• Gear shift drum</li> <li>• Upper crankcase</li> </ul>									

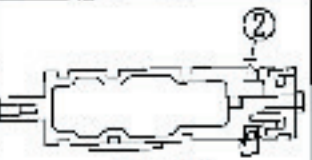
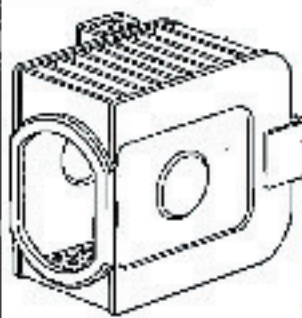
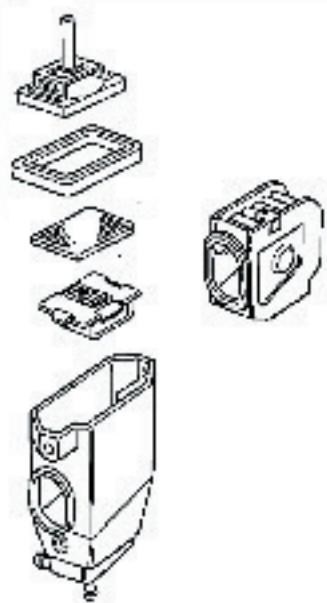
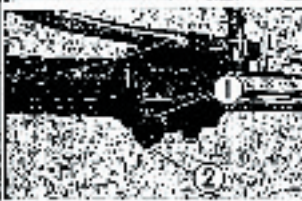
(Frame)

Part or Item	Model CB500	Model CB600	Modified part
Air cleaner	 <p>Fig. 346 Air cleaner element seal case</p>	 <p>Fig. 347</p> <p>- In connection with employment of the blow-by gas scavenging device, the air cleaner shape was changed.</p>	<ul style="list-style-type: none"> <li>- Air cleaner chamber</li> <li>- Element cover</li> <li>- Element cover seal</li> <li>- Element (wet type)</li> <li>- Flare seal</li> <li>- Air cleaner element (dry type)</li> </ul>
Final drive sprocket	Number of teeth: 88	Number of teeth: 97	
Turn signal/horn switch	 <p>Fig. 348</p> <ul style="list-style-type: none"> <li>① Turn signal switch</li> <li>② Horn switch</li> </ul>	 <p>Fig. 349</p> <ul style="list-style-type: none"> <li>① Turn signal switch</li> <li>② Horn switch</li> <li>③ Dimmer switch</li> </ul>	<ul style="list-style-type: none"> <li>- The turn signal/horn switch was changed to the turn signal/horn/dimmer switch (common with that of CB750).</li> </ul>
Starter/headlight/ignition switch	 <p>Fig. 350</p> <ul style="list-style-type: none"> <li>① Ignition switch</li> <li>② Headlight switch</li> <li>③ Starter switch</li> </ul>	 <p>Fig. 351</p> <ul style="list-style-type: none"> <li>① Ignition switch</li> <li>② Headlight switch</li> <li>③ Starter switch</li> </ul>	<ul style="list-style-type: none"> <li>- The starter/headlight/ignition switch shape was changed.</li> </ul>



## 10. ENGINE

### 1. CLUTCH

#### A. Disassembly

1. Drain the engine oil. (See page 20 of the CB500 Shop Manual issued separately).
2. Remove the kick starter pedal.
3. Remove the ten 6mm screws and the right crankcase cover.



Fig. 352 ① Right crankcase cover

4. Remove the clutch lifter rod.
5. Remove the four clutch pressure plate mounting bolts.
6. Remove the clutch lifter plate.

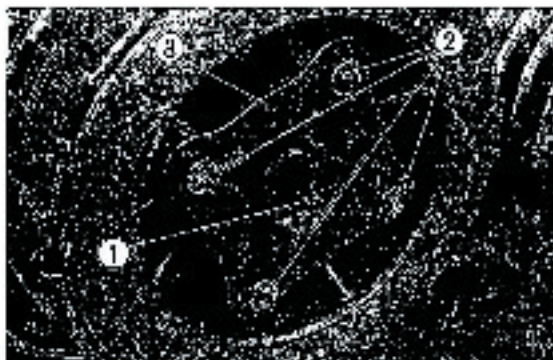

Fig. 353 ① Clutch lifter rod  
② Mounting bolts  
③ Lifter plate

7. Remove the 25mm snap ring and shim and remove the clutch assembly from the mainshaft.
8. Remove the clutch outer and inner at the same time.

(Refer to page 40, Fig. 110)

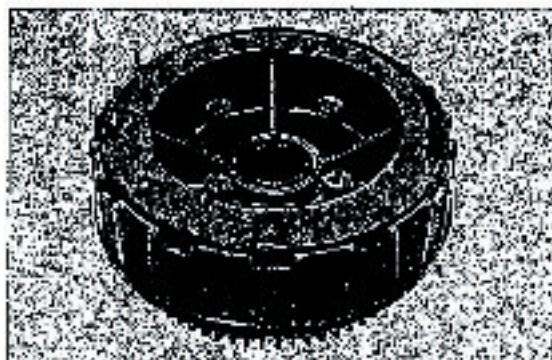

Fig. 354 ① Clutch assembly

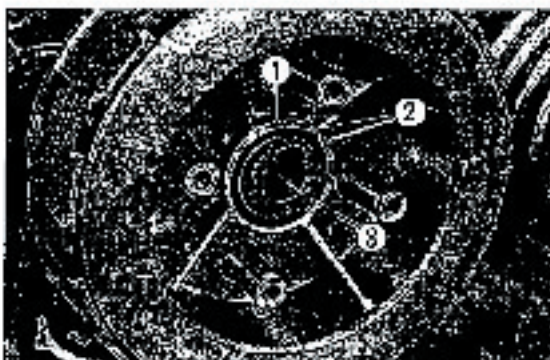

Fig. 355 ① 25mm snap ring  
② Shim  
③ Main shaft

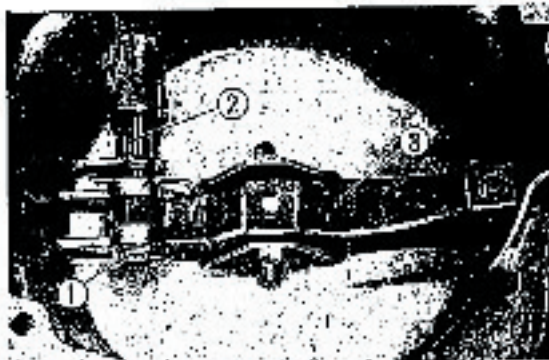

Fig. 356 (1) Cotter pin (2) Clutch adjusting lever (3) Clutch lever



Fig. 357 (1) 6mm nut



Fig. 358 (1) Clutch lever spring (2) 10mm washer



Fig. 359 (1) Clutch center (2) Friction discs and plates (3) Clutch outer (4) 25mm collar

9. Remove the cotter pin from inside the right crankcase cover and pull the clutch lever out.

10. Remove the 6mm nut and the clutch adjusting lever.

### B. Inspection

See page 41 of the CB500 Shop Manual issued separately.

Measurement of friction disc thickness.

Using a vernier caliper, measure the thickness of each friction disc. Replace a disc whose thickness is below the service limit.

Unit: mm (in.)	
Assembly standard	Service limit
2.7 (0.1063)	2.4 (0.0945)

### C. Assembly

1. Install and tighten the 6mm nut attaching the clutch adjusting lever.
2. As shown in Fig. 358, install the clutch lever spring and 10mm washer on the clutch lever. Insert the cotter pin and spread its ends.
3. Install the 25mm collar in the clutch outer.
4. Install the seven friction discs and six plates alternatively to the clutch center and to the clutch outer. Install to the mainshaft.

5. Attach a dial gauge to the end face of the clutch assembly to check for excessive looseness. If it exceeds 0.1 mm (0.0039 in.), install a washer or washers behind the snap ring. The washers are available in three thicknesses: 0.1 mm (0.0039 in.), 0.3 mm (0.0118 in.) and 0.5 mm (0.0197 in.).
6. Install the four clutch springs. Install the lifter plate and tighten the four 6mm bolts in a criss-cross pattern.
7. Insert the lifter rod.
8. Install the right crankcase cover and kick starter pedal.

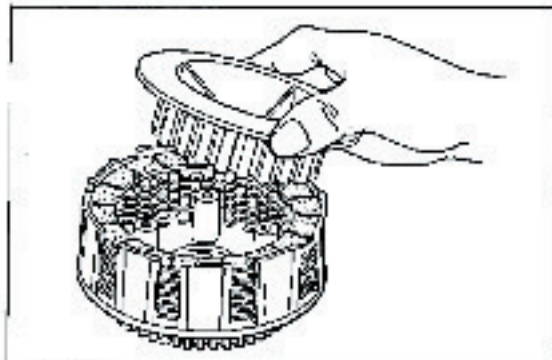

Fig. 380



Fig. 381



Fig. 362 ① Gearshift arm



Fig. 363 ① Shift drum neutral stop bolt  
② Shift drum stop bolt  
③ Shift drum stop ④ Neutral stop



Fig. 364 ① Bearing set plate on primary shaft side  
② Bearing set plate on shift drum side



Fig. 365 ① 6mm bolt ② Drum gearshift center  
③ Stop cam plate

## 2. GEARSHIFT MECHANISM

### A. Disassembly

1. Remove the clutch. (See page 121.)
2. Remove the gear change pedal.
3. While holding the gearshift arm down as shown in Fig. 362, pull the gearshift spindle out.
4. Remove the shift drum stop bolt, the neutral stop bolt, the shift drum stop and the neutral stop.
5. Remove the 6mm bolt and the bearing set plate on the primary shaft side.
6. Remove the two 6mm bolts and the bearing set plate on the gearshift drum side.
7. Remove the 6mm bolt, the drum stop cam plate and the drum gearshift center.

8. Separate the crankcase into the upper and lower parts and remove the transmission gears. (See page 43 of the CB500 Shop Manual issued separately.)
9. Remove the neutral stop switch from the gearshift drum.

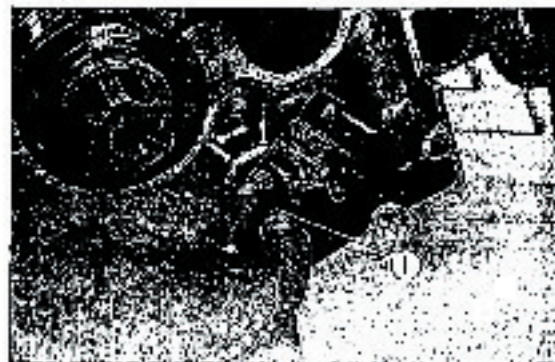

Fig. 365 ① Neutral stop switch

10. Remove the guide pin clip and guide pin and pull the gearshift drum from the upper crankcase.

#### B. Inspection

See page 41 of the CB500 Shop Manual issued separately.

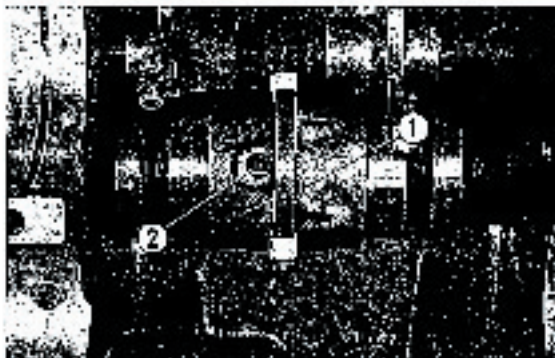

Fig. 367 ① Guide pin clip ② Guide pin

#### C. Assembly

1. Position the center gearshift fork on the drum as shown in Fig. 368.
2. Insert the guide pin into the center gearshift fork and secure with the guide pin clip.

#### NOTE:

Install the guide pin clip with it facing correctly. (See Fig. 367.)



Fig. 368 ① Center gearshift fork ② Drum

3. Put the right and left gearshift forks in the upper crankcase and insert the gearshift fork shaft as shown in Fig. 369.

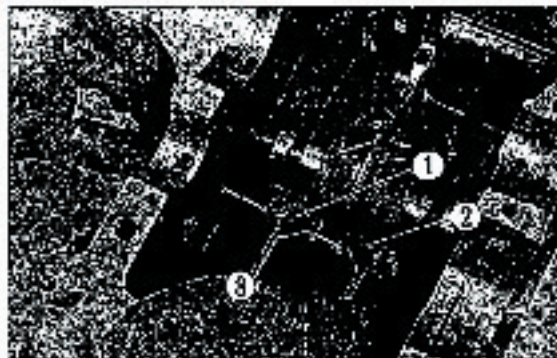

Fig. 369 ① Right gearshift fork  
② Left gearshift fork  
③ Gearshift fork shaft





Fig. 370

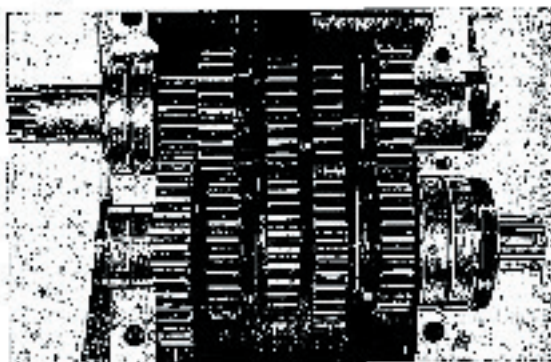

Fig. 371

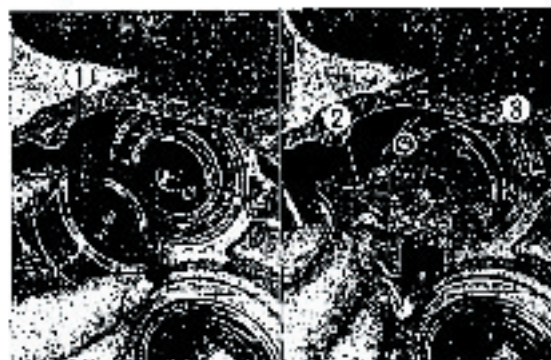

Fig. 372 ① Drum gearshift center  
② Drum stop cam plate  
③ Lug



Fig. 373 ① Bearing set plate on primary shaft side

4. Make sure that the gearshift forks are installed correctly and securely.

5. Install the neutral stop switch to the gearshift drum by fitting the lug into the groove in the drum and secure with the 6mm screw.

6. Install the transmission gears in the upper crankcase and put the upper and lower crankcases together. Install the primary shaft and tighten the crankcases securely.

7. Install the bearing set plate on the drum side and secure with the two 6mm bolts.

8. Install the drum gearshift center.

NOTE:

Properly fit the lug of the drum into the hole in the drum gearshift center.

9. Install the drum stop cam plate.

NOTE:

Properly fit the gearshift drum pin into the hole in the drum stop cam plate.

10. Install the bearing set plate on the drum side.

11. As shown in Fig. 373, install the gearshift drum stop spring to the drum stop and the neutral stop and tighten the drum stop bolt, and neutral stop bolt securely. Also tighten the bearing set plate on the primary shaft side as shown in Fig. 373.

12. Rotate the gearshift drum and check each component for smooth movement.
13. Install the gearshift arm and check to see if it moves smoothly and equally in both directions.
14. Install the clutch. (See page 121.)



Fig. 874

## 11. TROUBLE SHOOTING

### ENGINE

Trouble	Probable Causes	Remedies
Engine does not start	<ol style="list-style-type: none"> <li>Excessive piston ring or cylinder wear</li> <li>Seized valve in valve guide</li> <li>Seized piston</li> <li>Faulty valve timing</li> <li>Low or lack of compression pressure - Pressure leak</li> <li>Blown out cylinder head gasket</li> <li>Warped gasketing surfaces of the cylinder and cylinder head</li> </ol>	<p>Replace</p> <p>Replace</p> <p>Replace</p> <p>Adjust</p> <p>Lap the valve to obtain good valve seating or replace</p> <p>Replace</p> <p>Repair or replace</p>
Poor engine idling	<b>Valve Mechanism</b> <ol style="list-style-type: none"> <li>Incorrect tappet clearance</li> <li>Low or lack of compression pressure</li> <li>Excessive valve guide clearance</li> </ol>	<p>Adjust to standard value</p> <p>Repair</p> <p>Replace valve and guide</p>
Loss of power	<ol style="list-style-type: none"> <li>Valve sticking open</li> <li>Incorrect seating of valve</li> <li>Weak or broken valve spring</li> <li>Faulty valve timing</li> <li>Blown out cylinder head gasket</li> <li>Excessive cylinder and piston wear</li> <li>Worn, weak or broken piston ring</li> <li>Loose spark plug</li> </ol>	<p>Replace</p> <p>Lap valve</p> <p>Replace</p> <p>Check valve timing and adjust if necessary</p> <p>Replace</p> <p>Replace</p> <p>Replace</p> <p>Retighten</p>
Overheating	<ol style="list-style-type: none"> <li>Heavy carbon deposit on combustion chamber and piston head</li> <li>Lean fuel mixture</li> <li>Retarded ignition timing</li> <li>Low oil level, poor quality</li> <li>Extended operation in low gear</li> </ol>	<p>Remove carbon</p> <p>Adjust the carburetor</p> <p>Adjust ignition timing</p> <p>Add good grade oil</p>
Backfire	<ol style="list-style-type: none"> <li>Incorrect seating of intake valve</li> <li>Faulty valve timing</li> <li>Incorrect ignition timing</li> <li>Excessive spark plug gap</li> <li>Improper fuel</li> </ol>	<p>Check the valve seating</p> <p>Adjust</p> <p>Adjust</p> <p>Adjust the gap to 0.024~0.028 in. (0.5~0.7 mm)</p> <p>Replace</p>
White exhaust smoke	<ol style="list-style-type: none"> <li>Excessive cylinder and piston wear</li> <li>Overfilled engine oil</li> <li>Excessively high oil pressure</li> <li>Poor quality oil</li> </ol>	<p>Replace the piston</p> <p>Adjust the oil level</p> <p>Check the breather</p> <p>Replace with good quality oil</p>
Black exhaust smoke	Rich fuel mixture	Adjust the carburetor