



### 3. MAINTENANCE OPERATIONS

#### 1. TAPPET ADJUSTMENT

Adjust tappet clearance when the engine is cold.

**Note:**

Pistons are numbered left to right from the rider's position.

1. Remove the tank.
2. Loosen the tappet hole caps.
3. Remove the point cover and align the "T" (1-4) mark on the spark advancer to the timing mark when the No. 1 piston is at top-dead-center of the compression stroke.
4. Check and adjust valve tappet clearances indicated by "O" in the chart below.
5. Measure the clearances using a feeler gauge. Adjust by loosening the lock nut and turning the adjusting screw. Tighten the lock nut.

Valve tappet clearances:

INTAKE—0.05 mm (0.002 in.)

EXHAUST—0.08 mm (0.003 in.)

5. Rotate the crankshaft one revolution and realign the "T" (1-4) mark on the spark advancer to the timing mark. In this position, the No. 4 piston is at top-dead-center of the compression stroke. Check and adjust the valve tappet clearances indicated by "X" in the chart below. See step 5 above for proper valve tappet clearances.

	No. 1 cylinder	No. 2 cylinder	No. 3 cylinder	No. 4 cylinder
Intake valve	O	X	O	X
Exhaust valve	O	O	X	X

**Note:**

- Hold the adjusting screw so that it does not turn when tightening the lock nut.
- Make sure the clearance is not disturbed when the lock nut is tightened.

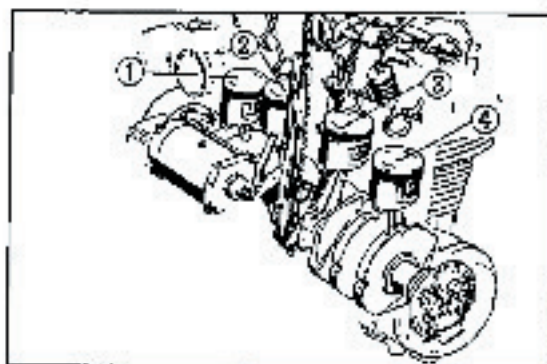

Fig. 1 ① No. 1 piston ② No. 2 piston  
③ No. 3 piston ④ No. 4 piston

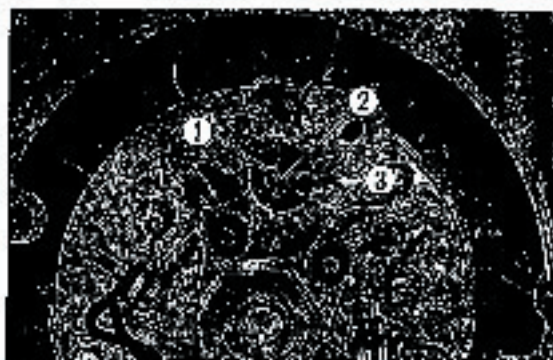

Fig. 2 ① T mark ② 1-4 mark  
③ Timing mark

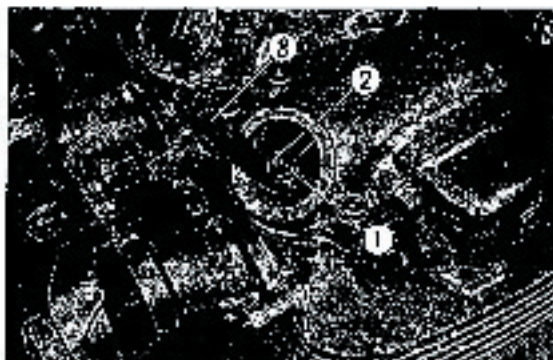

Fig. 3 ① Lock nut ② Feler gauge  
③ Adjusting screw



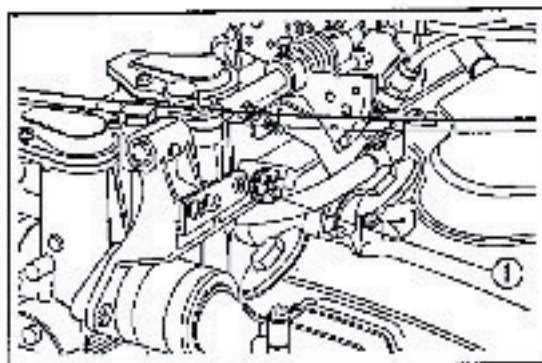

Fig. 4 ① Throttle stop screw

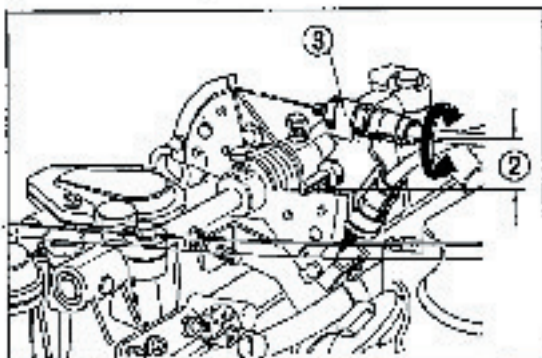

Fig. 5 ① Throttle stop screw  
② 49±1.5 mm (1.929±0.059 in.)  
③ Stay

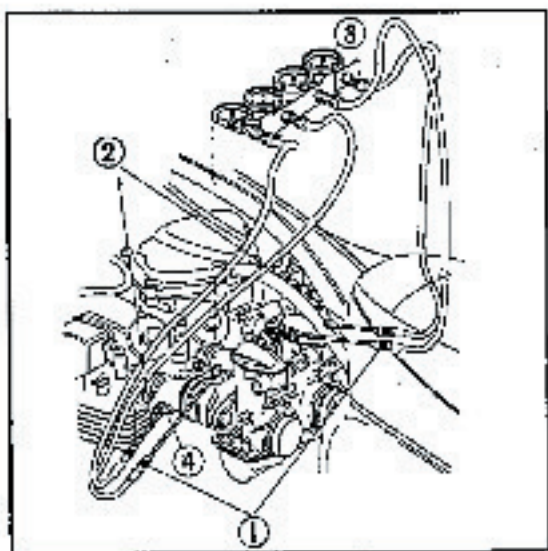

Fig. 6 ① A adaptor  
② B adaptor  
③ Vacuum gauge  
④ Plug hole

## 2. CARBURETOR ADJUSTMENT

Adjust the carburetor after warming up the engine (60-70°C/140-158°F).

### Idle adjustment

Adjust the engine idle speed to 950-1050 rpm with the throttle stop screw. Turn the screw clockwise to increase the idle speed and counterclockwise to decrease the idle speed.

### Synchronization adjustment

1. Remove the fuel tank.

Note:

Position the tank about 50 cm (20 in.) higher than the mounting position and reconnect with a longer fuel line.

2. Adjust the throttle stop screw so that the throttle lever is  $49 \pm 1.5$  mm ( $1\frac{1}{2} \pm \frac{1}{16}$  in.) from the stay.
3. Install the vacuum gauge in the intake manifold. Remove the plugs from the intake manifold. Install the long A adaptors of the vacuum gauge to the two inside manifolds and the short B adaptors to the outside manifolds.
4. Start the engine, loosen the adjusting lock nuts and turn the adjusting screws so that all four carburetors are uniform (16-24 cm Hg) on the vacuum gauge (IAC 39340).

Turn the screws clockwise to increase vacuum. Turn the screws counterclockwise to decrease vacuum. All the carburetors should be adjusted to within 3.0 cm Hg of each other.

Note:

If the gauge needle is oscillating over a wide range, dampen the movement with the vacuum adjuster on the gauge.

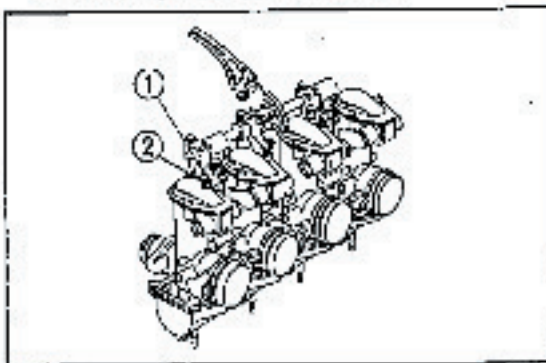

Fig. 7 ① Screw  
② Lock nut



5. Snap the throttle back several times and recheck the vacuum pressure after the four carburetors indicate the same vacuum pressure.

Repeat the adjustment in step 4 if the vacuum pressures lack uniformity.

Check the following items if the vacuum pressure is less than 15 cm Hg for any of the carburetors:

1. Be sure the ignition timing is  $-5^{\circ}/1,150 - 30^{\circ}/2,500$  rpm BTDC.
  2. Check the tappet clearances.  
Intake: 0.05mm (0.002in.)  
Exhaust: 0.08mm (0.003in.)
  3. Check the spark plug gap.  
Gap: 0.6-0.7 mm (0.024-0.028in.)
  4. Check the compression pressure.  
Pressure: 11-12 kg/cm<sup>2</sup>  
(156.45-170.67 psi.)
6. After all four carburetors have been adjusted to the same vacuum pressure, adjust the throttle stop screw to an idle speed of 950~1,050 rpm.
  7. Adjust the air screw on each carburetor. (The standard adjustment for the air screws is  $1 \pm 3/8$  turns open from the fully closed position.)
  8. Readjust the engine idle speed to 950-1,050 rpm with the throttle stop screw.

**Note:**

Tighten the intake manifold plugs after synchronizing the carburetors.

**Throttle Cable Adjustment**

1. Turn the adjuster counterclockwise at the handlebar end to increase free play in the throttle cable. Turn it clockwise to decrease the free play.

**Note:**

Leave about 3 mm (0.12in) range of adjustment at the cable adjuster for final micro-adjustment.

2. Loosen the cable lock nut and turn the adjuster at the carburetor end to provide 3~4 mm ( $1/8 - 1/2$  in.) free play at the throttle grip fange.

**Note:**

The throttle lever should hit the eccentric pin when the grip is forced to the fully closed position. If it doesn't, replace the return cable with a new one.

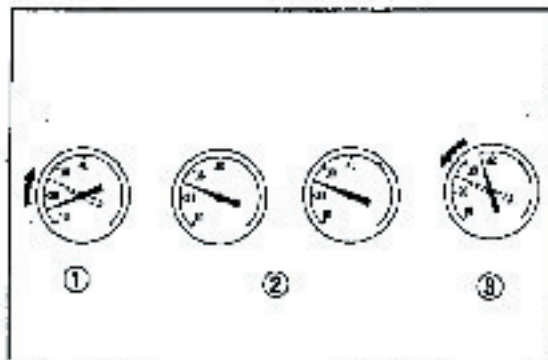

Fig. 8 ① Low vacuum ② Normal ③ High vacuum

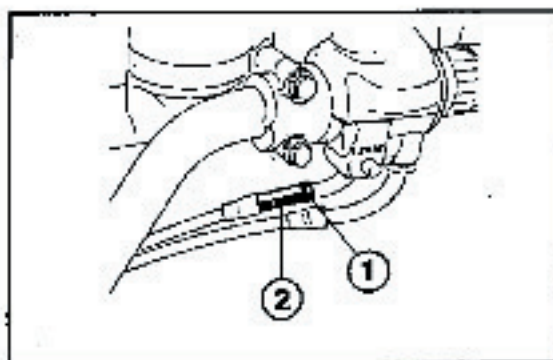

Fig. 9 ① Lock nut ② Adjuster

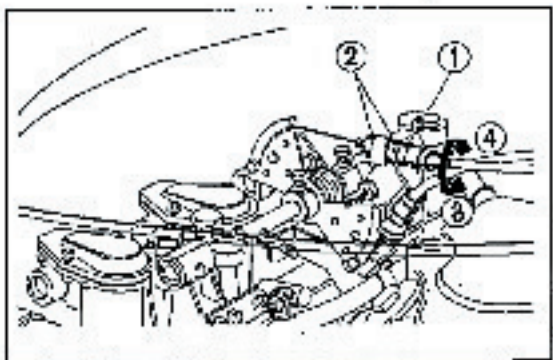

Fig. 10 ① Adjuster ② Lock nut ③ Decrease ④ Increase



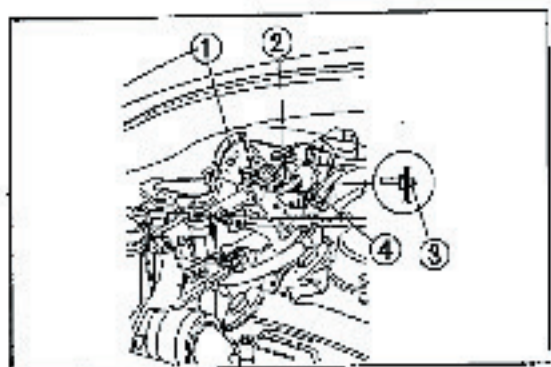

Fig. 11 ① Throttle lever ② Lock nut  
③ Eccentric pin  
④ 2~3 mm (0.08~0.12 in.)

#### Overtravel stopper adjustment

Loosen the lock nut and turn the eccentric pin. Clearance between the throttle lever and the eccentric pin should be 2~3 mm (0.08~0.12 in.).

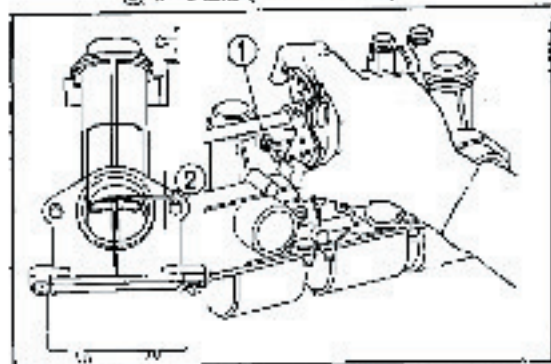

Fig. 12 ① Stop screw ② 0~1.0 mm (0~0.04 in.)

#### Full throttle opening stopper adjustment

Adjust the stop screw so that the throttle valve extends 0~1.0 mm (0~0.04 in.) above the throttle bore in the fully open position.



Fig. 13 ① Slipper ② 1-4 points  
③ 2-3 points

### 3. BREAKER POINT GAP AND IGNITION TIMING ADJUSTMENT

Check the condition of the contact points, point gap and ignition timing. Adjust the ignition timing of the 1-4 points first.

#### Breaker point gap adjustment, 1-4 points

1. Rotate the crankshaft until the contact breaker slipper comes up on the highest position of the cam lobe. Measure the point gap with a feeler gauge.

Standard point gap: 0.3~0.4 mm (0.012~0.016 in.)

2. Loosen the screw ② and move the breaker point assembly if it needs to be adjusted.

#### Breaker point gap adjustment, 2-3 points

Adjust the 2-3 point gap in the same manner as the 1-4 points by loosening the screw ②.

#### Note:

Clean the point surfaces with a point file or an oil stone if they are pitted or rough.



Fig. 14 ① Screw ② Screw ③ Breaker ④ 2-3 points  
⑤ 1-4 points



### Ignition timing adjustment, 1-4 points

1. Connect a 12V test lamp to 1-4 points primary wire (blue) and to ground. (See Fig. 15)
2. Turn the main switch to the "ON" position.
3. Rotate the crankshaft clockwise slowly. If the test lamp comes on when the "F" (1-4) mark on the spark advancer is aligned to the timing mark, the timing is correct.
4. If the adjustment is necessary, align the "F" (1-4) mark to the timing mark and loosen the screws ②, and then move the base ③ until the lamp goes on. Tighten the screws.

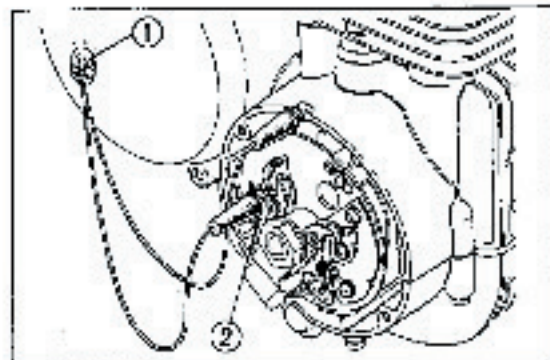

Fig. 16 ① 12V Lamp ② Blue cord

### Ignition timing adjustment, 2-3 points

1. Connect the 12V test lamp to the primary cord (yellow) of the opposite contact breaker and align the "F" (2-3) mark to the timing mark.
2. Loosen the screw ② and move the base ③ as shown above.



Fig. 16 ① "F" (1-4) Mark ② Timing mark

### Ignition timing adjustment with a stroboscopic timing light

The use of the stroboscopic timing light is recommended to obtain the most accurate timing.

1. Plug the timing light cord into the timing light receptacle.
2. Remove the spark plug cap from the No. 4 cylinder and install the timing attachment between the spark plug and the cap.
3. Connect the high tension cord of the timing light to the timing attachment, position the switch knob to TIMING, and start the engine. The timing light will flash.
4. Aim the timing light toward the timing mark and make sure the "F" (1-4) mark and the timing mark are aligned. Increase the engine rpm to approximately 2000 rpm. At this speed, if the timing mark is between the two index lines located 23.5~26.5° before the "F" mark, the ignition timing at full advance condition is satisfactory.



Fig. 17 ① Screw ② Base ③ Base ④

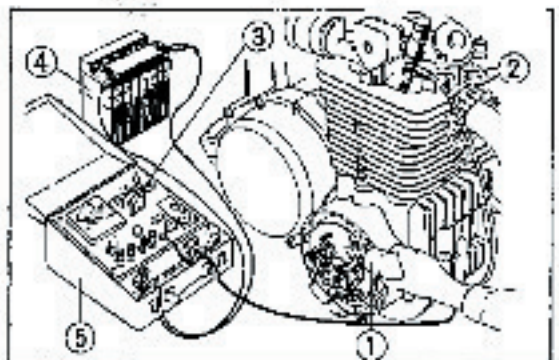

Fig. 18 ① Timing light ② Timing attachment ③ Battery ④ Service tester  
 ⑤ Switch knob



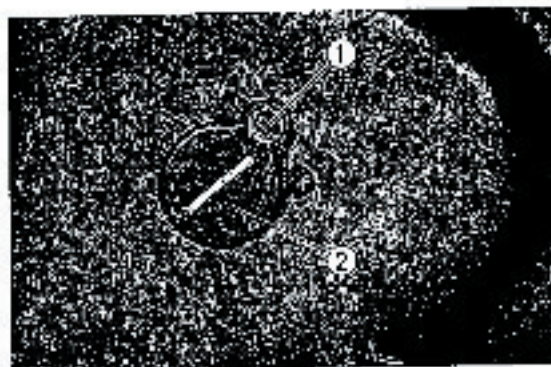

Fig. 19 ① Lock bolt ② Adjuster

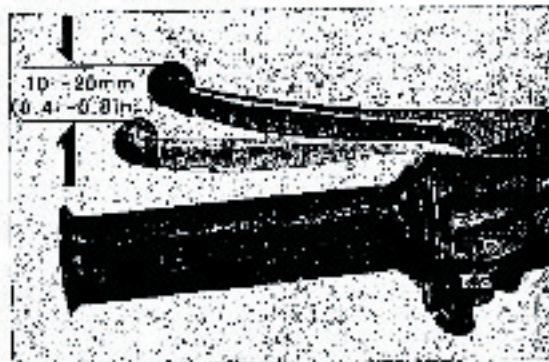

Fig. 20

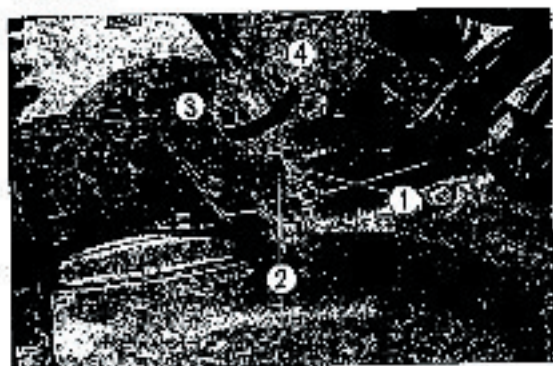

Fig. 21 ① Lock nut ② Adjuster ③ Increase free play ④ Decrease free play

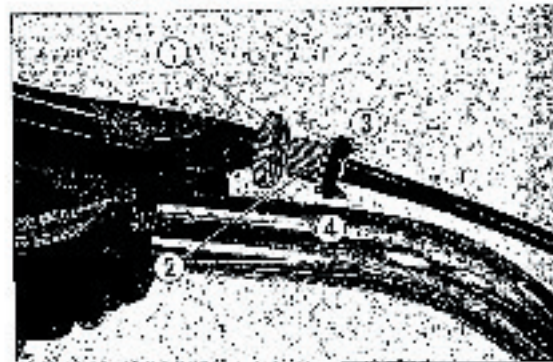

Fig. 22 ① Lock nut ② Adjuster ③ Increase free play ④ Decrease free play

5. Remove the spark plug cap from the No. 3 cylinder and install the timing attachment between the spark plug and the cap. Check the ignition timing ("P" 2-3) as described in steps 1-4.
6. Adjust if the timing is incorrect.

#### 4. CLUTCH ADJUSTMENT

1. To provide free play in the clutch cable, loosen the clutch adjuster lock bolt.
2. Turn the adjuster clockwise until a slight resistance is felt, and then turn counterclockwise about 3 mm (1/8 in.). At that point, tighten the lock bolt.
3. Adjust free play in the clutch cable at the lock nut and adjuster on the engine. The play should be 10~20 mm (0.4~0.8 in.). Perform micro adjustment with the adjuster at the clutch lever.

#### 5. CAM CHAIN ADJUSTMENTS

Perform cam chain tension adjustment in the following manner.

1. Remove the tappet hole caps from the No. 1 cylinder.
2. Remove the point cover, and align the "T" (1-4) mark to the timing mark.
3. Check both valves of the No. 1 cylinder. If both valves are free, proceed to the next step. If either or both of the valves are



tight, rotate the crankshaft 360°, and proceed with the next step.

4. Rotate the crankshaft clockwise until the spring peg on the advancer assembly at the 1-4 position is at the right of a line from the timing mark. This position is 15° ATDC.
5. At this point, loosen the lock nut so that proper chain tension can be obtained automatically.
6. Retighten the lock nut, and reinstall the point cover and tappet covers.

### 6. SPARK PLUG INSPECTION

Remove the spark plug with a spark plug wrench and check the gap and the insulator for damage or fouling.

1. Clean the plug with a spark plug cleaner or a wire brush.
2. Check the gap with a feeler gauge and adjust the opening to the standard 0.6~0.7 mm (0.02~0.03 in.).
3. Replace the plug or plug gasket if the insulator or gasket is damaged.

Standard spark plugs: **D-7ES (NGK)**  
**X 22 ES (DENSO)**

### 7. ENGINE OIL INSPECTION AND CHANGE

#### Oil Level Inspection

Check the oil level with the dipstick gauge without screwing it into the case. If the level is below the lower mark on the gauge, add oil to the upper mark.

Recommended oil classification:

Honda 4-strokes oil or equivalent

SAE 10W-40 or SAE 20W-50

#### Oil change

Perform the oil change while the engine is warm so that the oil will drain properly.

1. Loosen the drain bolt and remove the filler cap to assist draining.
2. Remove the oil filter to drain the oil completely.
3. Tighten the drain bolt and fill with 2.5 l (2.6 U.S. qt., 2.2 Imp. qt.) of clean oil through the filler opening. Add oil as necessary to bring the oil level to the upper mark on the gauge.

Oil capacity: 3.0 liters (3.2 U.S. qt.,  
2.6 Imp. qt.)



Fig. 23 ① Nut ② Adjusting screw ③ Spring peg

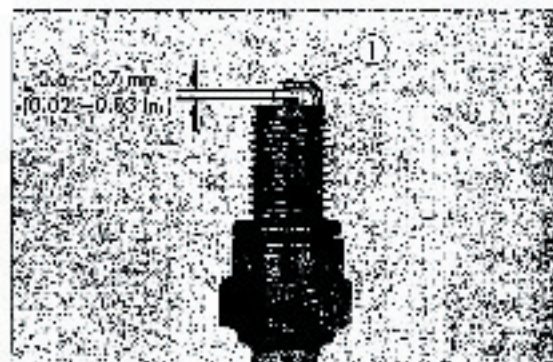

Fig. 24 ① Gap

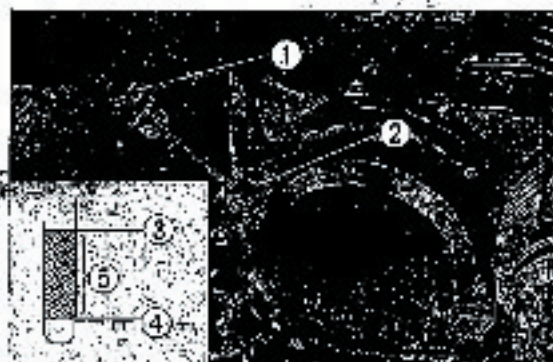

Fig. 25 ① Filler cap ② Oil level gauge ③ Lower level ④ Serviceable range ⑤ Upper level

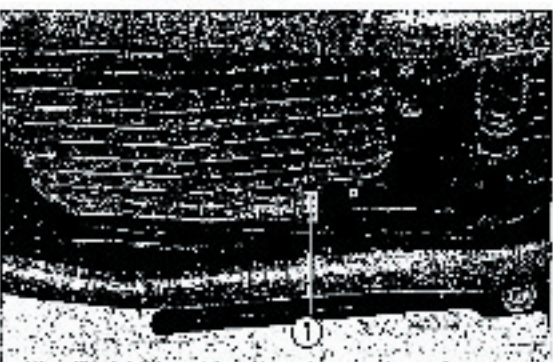

Fig. 26 ① Drain bolt





Fig. 27 ① Oil filter center bolt



Fig. 28 ① Oil filter cover ② Washer  
③ Oil filter element ④ Oil filter center bolt  
⑤ Spring ⑥ O-ring



Fig. 29 ① Stopper bolt lock nut ② Disc  
③ Stopper bolt

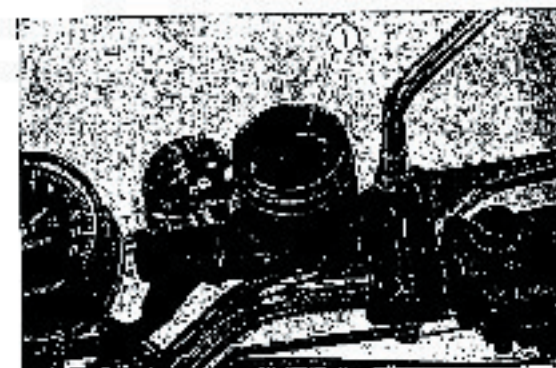

Fig. 30 ① Level mark

## 8. OIL FILTER SERVICING

Service the oil filter when changing the engine oil.

1. Loosen the oil filter center bolt and remove the filter element.

Note:

- A small amount of oil will drip from the filter when it is removed.
- When reinstalling the element, replace all parts. Any pieces of rubber left on the seat will cause poor sealing.
- Replace the oil filter element every 6,000 km (4,000 miles).

## 9. BRAKE INSPECTION AND ADJUSTMENT

### Adjusting Brake Caliper

Whenever the brake pads are replaced, the brake caliper must be adjusted. The adjustment is made in the following manner, so that there is a small clearance between the fixed friction pad and the brake disc.

1. Raise the front wheel off the ground using a block or jack.
2. Loosen the caliper stopper bolt lock nut.
3. Turn the stopper bolt in direction ④ until the friction pad contacts the brake disc. When the wheel is rotated, a slight drag should be noticed.
4. While rotating the front wheel, turn the stopper bolt in direction ③ until the front wheel rotates freely.
5. Turn the stopper bolt 1/2 turn in direction ④ further and tighten the lock nut.

### Replenishing Brake Fluid

Remove the reservoir cap, washer and diaphragm, and if the level is lower than the level mark engraved inside the reservoir, fill the reservoir with **DOT 3 BRAKE FLUID** to the level mark. Reinstall the diaphragm and washer, and tighten the reservoir cap securely.

Note:

- Do not mix brands of brake fluid. A chemical reaction may occur or brake problems could result.
- Do not use any other fluid in the brake system.



- Remove any brake fluid which may have spilled on a painted surface, rubber parts, and meter components. It may produce a chemical reaction and damage those parts.

### Brake Pad Inspection

Replace pads A and B with new ones when either of the pads is worn to the red serviceable limit mark around the pad.

### Brake Bleeding

The brakes must be bled subsequent to work performed on the brake system, when the lever becomes soft or spongy, or when lever travel is excessive. The procedure is best performed by two mechanics.

- Remove the dust cap from the bleeder valve and attach the bleeder hose.
- Place the free end of the bleeder hose in a glass container which has some hydraulic brake fluid in it so that the end of the hose can be submerged.
- Fill the reservoir using only the recommended brake fluid. Screw the cap partially on the reservoir to prevent entry of dust.
- As shown in Fig. 33 attach a piece of rubber about 15mm thick to the end of the handle grip to decrease the stroke as measured at the tip of the handle lever. Pump the brake lever several times until pressure can be felt. Holding the lever tight, open the bleeder valve about  $\frac{1}{2}$  turn and squeeze the lever all the way down.  
Do not release the lever until the bleeder valve has closed again. Repeat this procedure until bubbles cease to appear in the fluid at the end of the hose.
- Remove the bleeder hose, tighten the bleeder valve and install the bleeder valve dust cap.
- Do not allow the fluid reservoir to become empty during the bleeding operation or air will enter the system again. Replenish the fluid as often as necessary while bleeding.
- Check for proper effect of bleeding and absence of leaks in the front brake lines while holding pressure against the brake lever. Replenish the fluid in the reservoir when bleeding is completed. Reinstall the diaphragm, washer and reservoir cap and tighten.

After the hydraulic brake system has been drained, it should be filled as outlined below.

- Fill the fluid reservoir.
- Open the bleeder valve by  $\frac{1}{2}$  turn, squeeze the brake lever, close the valve and release the brake lever. This procedure must be repeated in this sequence until hydraulic fluid begins to flow through the bleeder hose. After filling the hydraulic system with fluid, proceed with the actual bleeding operation.

#### Note:

- Brake fluid which has been pumped out of the system must not be used again.
- Brake fluid will damage the paint finish and instrument lenses.

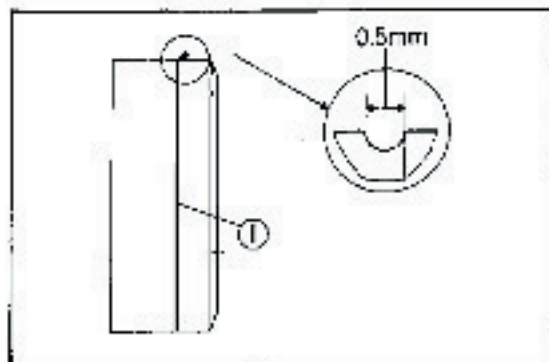

Fig. 31 ① Red line



Fig. 32 ① Diaphragm ② Brake fluid ③ Master cylinder

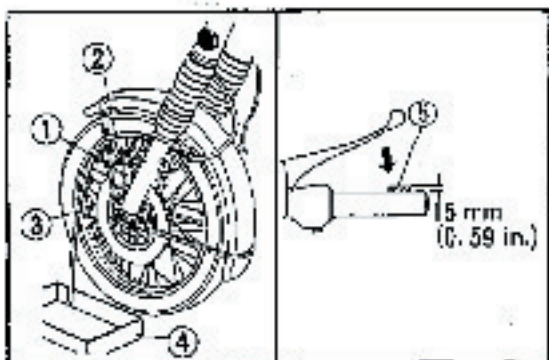

Fig. 33 ① Caliper ② Bleeder hose ③ Rubber ④ Bleeder ⑤ Drip pan





Fig. 34



Fig. 35 ① Adjuster nut ② Decrease free play  
③ Increase free play



Fig. 36 ① Seat lever ② Seat lock



Fig. 37 ① Air cleaner element ② Spring clip

#### Rear Brake Adjustment

1. Normal free play at the end of the brake pedal is 2-3 cm ( $\frac{1}{4}$ ~ $1\frac{1}{16}$  in.).

2. Perform the adjustment with the adjuster nut.

#### 10. AIR CLEANER ELEMENT SERVICING

1. Open the seat and remove the tool tray.
2. Pull the spring clip out and remove the cleaner element.
3. Clean the element by tapping it lightly and blowing compressed air from inside.